



2/2-way Diaphragm Valve with plastic body, pneumatically operated, DN 15-100

- Applications with aggressive media
- Flow-optimised body with zero dead volume
- Self-draining installation possible
- Removable radial true union, spigot and flange connections

For process valves with decentralized automation see ELEMENT Type 2103 (Start 2016)



Type 2030 can be combined with...



Type 8697

Electrical position feedback



Type 6012/6014 P

Pilot valve

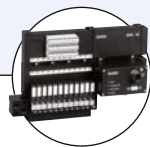

Type 8640/8644

Valve block



Type 3233

Manually-operated valve

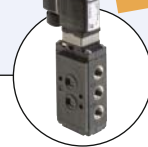

Type 6519 NAMUR

Solenoid valve

Pilot controlled diaphragm valve with piston actuator and diaphragm seal. As standard, actuator from PA. The flow optimised and zero dead volume valve body makes high flow rates possible.

Installation for self-draining

$\alpha = 15^\circ$ up to 30° plus 3° up to 5° inclination to pipe axis

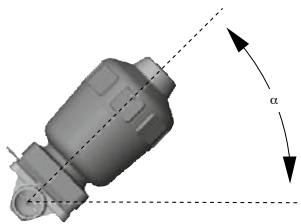

Technical data

Orifice (diaphragm size)	DN 15-100
Body materials	PVC-U, PP, PVDF
Actuator material	PA polyamide (PPS on request)
Seal material	EPDM, PTFE/EPDM
Media	Neutral gases and liquids, aggressive or abrasive media
Viscosity	Up to viscous
Media temperature	See charts p. 2
Ambient temperature	-10 to +60°C (PA) Actuator size ≥ 175 mm: -10 to +50°C
Control medium	Neutral gases, air
Port connections	DN 15-50: True union and spigot connections DN 65: Loose flanges DN 80-100: Fixed flanges
Installation	As required, preferably with actuator in upright position

Media temperature

Pressure-temperature compatibility charts

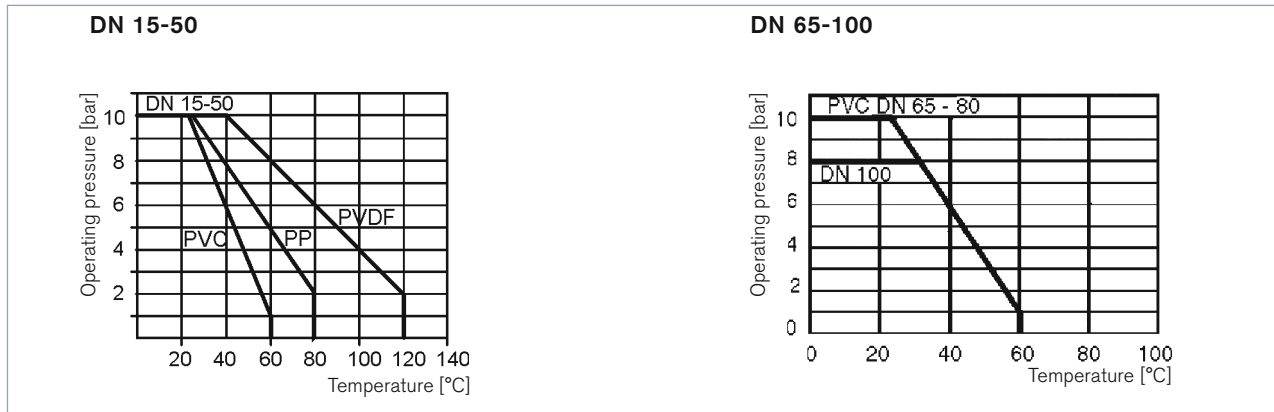

Important for the material selection!

Note that the permissible operating pressure is dependent on the media temperature.

Materials

DN 15-50

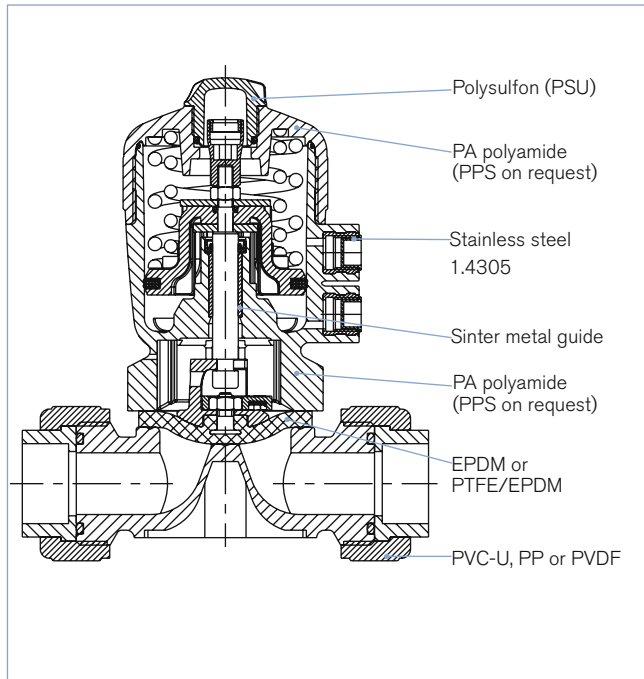

DN 65-100

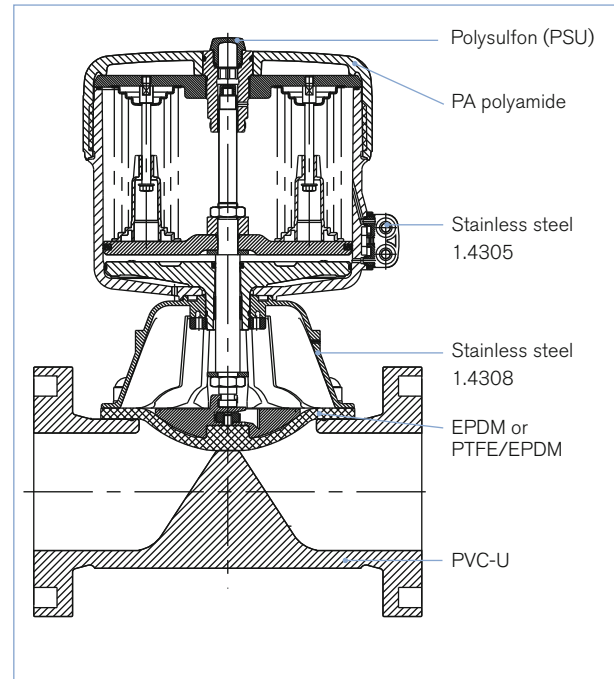

Approvals

Suitable for foodstuffs



- The composition of the EPDM and PTFE/EPDM diaphragms corresponds to the *Code of Federal Regulations*, published by the *FDA* (Food and Drug Administration, USA).

Ordering chart for diaphragm valves with piston actuator (other versions on request)

Body in PVC-U with true union or spigot connections
DN 15-50

Control function	Port connection [mm]	Orifice Diaphragm size [mm]	Actuator size Ø [mm]	Kv value water [m³/h]	Minimum pilot pressure [bar]	Operating pressure [bar]	Item no. true union
Seal material EPDM							
A 2/2-way, NC by spring action	20	15	50	3.0	5.0	8.5	262 212
				63	3.5	5.0	10
	25	20	63	7.0	5.5	10	262 740
	32	25	80	11.0	5.5	10	262 743
	40	32	100	18.0	5.5	10	262 745
	50	40	100	24.0	5.5	6.5	262 747
			125	26.0	5.5	10	262 748
63	50	125	43.0	5.5	8	262 750	
B 2/2-way, NO by spring action	20	15	50	3.0	see chart 1 on p. 5	10	262 252
	25			63		7.0	10
	32	25	80	11.0		10	262 754
	40	32	100	18.0	see chart 2 on p. 5	10	262 756
	50	40	100	24.0		10	262 757
			125	43.0		10	262 759
	63	50	125	43.0	10	262 759	
Seal material PTFE/EPDM							
A 2/2-way, NC by spring action	20	15	50	3.0	5.0	5	262 237
				63	3.5	5.0	10
	25	20	63	7.0	5.5	5	262 760
			80	7.0	5.0	10	262 742
	32	25	80	11.0	5.5	7.5	262 744
	40	32	100	18.0	5.5	8	262 746
			125	26.0	5.5	10	262 749
63	50	125	43.0	5.5	7	262 751	
B 2/2-way, NO by spring action	20	15	63	3.5	see chart 3 on p. 5	10	262 306
	25			80		7.0	10
	32	25	80	11.0		10	262 755
	40	32	100	18.0	see chart 4 on p. 5	10	on request
	50	40	125	26.0		10	262 758
			125	43.0		10	274 572

Further versions on request

**Materials**

Actuator: PPS

**Control function**

I Double-acting actuator

**Port connection**

Spigot

Ordering chart for diaphragm valves with piston actuator (other versions on request)

Body in PP with true union or spigot connections
DN 15-50

Control function	Port connection [mm]	Orifice Diaphragm size [mm]	Actuator size Ø [mm]	Kv value water [m³/h]	Minimum pilot pressure [bar]	Operating pressure [bar]	Item no. true union	Item no. spigot
Seal material EPDM								
A 2/2-way, NC by spring action	20	15	50	3.0	5.0	8.5	154 768	141 447
			63	3.5	5.0	10	154 769	141 448
	25	20	63	7.0	5.5	10	154 782	141 859
			80	11.0	5.5	10	154 786	141 467
			100	18.0	5.5	10	154 788	141 474
			100	24.0	5.5	6.5	154 790	141 480
			125	26.0	5.5	10	154 791	141 481
63	50	125	43.0	5.5	8	154 794	141 489	
B 2/2-way, NO by spring action	20	15	50	3.0	see chart 1 on p. 5	10	154 805	141 495
			63	7.0		10	154 808	141 505
			80	11.0		10	154 811	141 863
	25	20	100	18.0	see chart 2 on p. 5	10	154 813	141 523
			100	24.0		10	154 815	141 529
			100	26.0		10	154 818	141 538
			125	43.0		10	154 818	141 538
Seal material PTFE/EPDM								
A 2/2-way, NC by spring action	20	15	50	3.0	5.0	5	154 770	144 295
			63	3.5	5.0	10	154 781	141 454
	25	20	63	7.0	5.5	5	154 784	144 299
			80	7.0	5.0	10	154 785	141 464
			80	11.0	5.5	7.5	154 787	141 471
			100	18.0	5.5	8	154 789	141 477
			100	24.0	5.5	6.0	154 792	144 303
63	50	125	43.0	5.5	10	154 793	141 486	
B 2/2-way, NO by spring action	20	15	63	3.5	see chart 3 on p. 5	10	154 807	141 502
			80	7.0		10	154 810	141 513
			80	11.0		10	154 812	141 520
	25	20	100	18.0	see chart 4 on p. 5	10	154 814	141 526
			125	26.0		10	154 817	141 535
			125	43.0		10	154 819	141 541
			125	43.0		10	154 819	141 541



Further versions on request



Materials

Actuator: PPS



Control function

I Double-acting actuator

Ordering chart for diaphragm valves with piston actuator (other versions on request)

Body in PVDF with true union or spigot connections
DN 15-50

Control function	Port connection [mm]	Orifice Diaphragm size [mm]	Actuator size Ø [mm]	Kv value water [m³/h]	Minimum pilot pressure [bar]	Operating pressure [bar]	Item no. true union	Item no. spigot
Seal material PTFE/EPDM								
A 2/2-way, NC by spring action	20	15	50	3.0	5.0	5	154 796	144 296
			63	3.5	5.0	10	154 797	141 453
	25	20	63	7.0	5.5	5	154 798	144 300
			80	7.0	5.0	10	154 799	141 463
	32	25	80	11.0	5.5	7.5	154 800	141 470
			40	18.0	5.5	8	154 801	141 476
	50	40	100	24.0	5.5	6.0	154 802	144 337
125			26.0	5.5	10	154 803	141 485	
63	50	125	43.0	5.5	7	154 804	141 491	
B 2/2-way, NO by spring action	20	15	63	3.5	see chart 3 underneath	10	154 820	141 501
			25	7.0		10	154 821	141 512
			32	11.0		10	154 822	141 519
	40	32	100	18.0	see chart 4 underneath	10	154 823	141 525
			50	24.0		10	154 824	141 534
			63	43.0		10	154 825	141 540

Further versions on request

**Materials**

Actuator: PPS

**Control function**

I Double-acting actuator

Body in PVC-U with flange connection
DN 65-100

Control function	Port connection	Orifice Diaphragm size [mm]	Actuator size Ø [mm]	Kv value water [m³/h]	Minimum pilot pressure [bar]	Operating pressure [bar]	Item no. flanges
Seal material EPDM							
A 2/2-way, NC by spring action	Loose flanges	65	125	55.0	5.5	7	149 295
			175	60	4.5	8	147 838
	Fixed flanges	80	175	100	5.0	5	147 840
			225	100	5.0	10	147 842
Fixed flanges	100	225	160	5.0	8	147 843	
Seal material PTFE/EPDM							
A 2/2-way, NC by spring action	Loose flanges	65	125	55	5.5	4.5	149 296
			175	60	4.5	5	147 845
	Fixed flanges	80	175	100	5.0	4.5	147 847
			225	100	5.0	10	147 849
Fixed flanges	100	225	160	5.0	4	147 850	

Pilot pressure charts for control function B

Seal material EPDM

Chart 1 – orifice 15-25

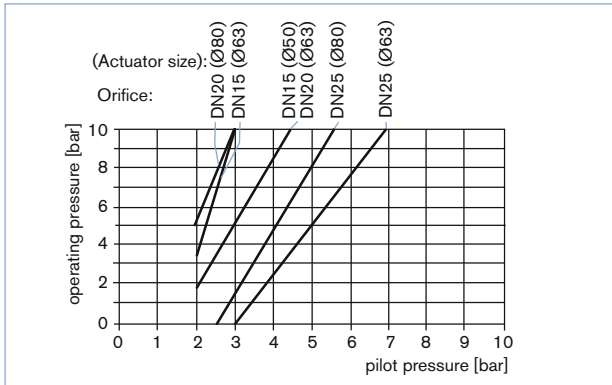
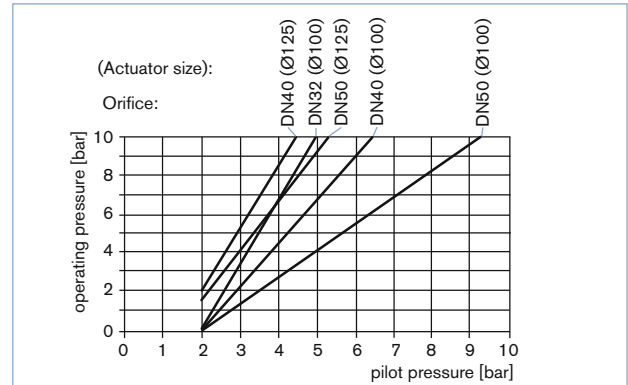

Chart 2 – orifice 32-50



Seal material PTFE/EPDM (EA)

Chart 3 – orifice 15-25

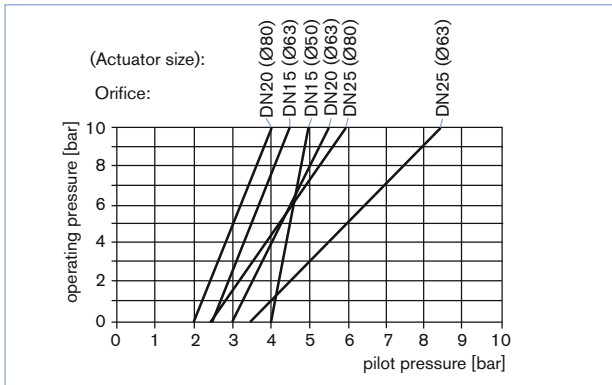
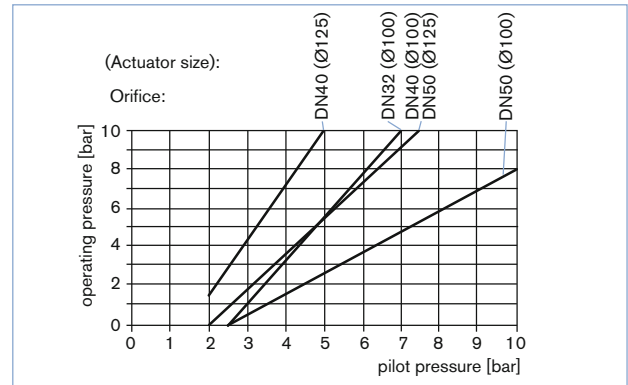

Chart 4 – orifice 32-50



Ordering chart for accessories

3/2-way pilot valves with banjo bolts

Seal material valve FKM, seal material banjo bolt NBR

Valve for actuator size [Ø mm]	Type	Pressure inlet P (valve body)	Service port A (banjo bolt)	Orifice [mm]	Qn value air [l/min]	Pressure range [bar]	Electrical coil connection Ind. Std.	Power consumption [W]	Item no. Voltage/frequency [V/Hz]
									024/DC 230/50
50	6012P	G 1/4	G 1/8	1.2	48	0-10	Form B	4	552 295 552 298
63	6012P	Tube fitting ø6 mm	G 1/4	1.2	48	0-10	Form B	4	552 283 552 286
63-125	6014P	G 1/4	G 1/4	2	120	0-10	Form A	8	424 103 424 107
175-225	6014P	G 1/8	G 1/4	2.5	174	0-6	Form A	8	786 014 786 015
175-225	0331P	G 1/4	G 1/4	3	194	0-10	Form A	8	- 041 233

Cable plug Type 2507, Form B or Type 2508, Form A

	Item no.
Type 2507, Form B Industrial standard, 0 to 250 V without circuitry (Type 6012 P)	423 845
Type 2508, Form A acc. DIN EN 175301-803, 0 to 250 V without circuitry (Type 6014 P, Type 0331P)	008 376

For further accessories see the datasheet for Type 1062 or the accessories datasheet, Type 2XXX for the full options programme.

Note: For design reasons, some of the accessories cannot be supplied for actuator size Ø 40, 175 and 225 mm. Please request the accessories datasheet Type 2XXX.

Dimensions [mm]

DN 15-50

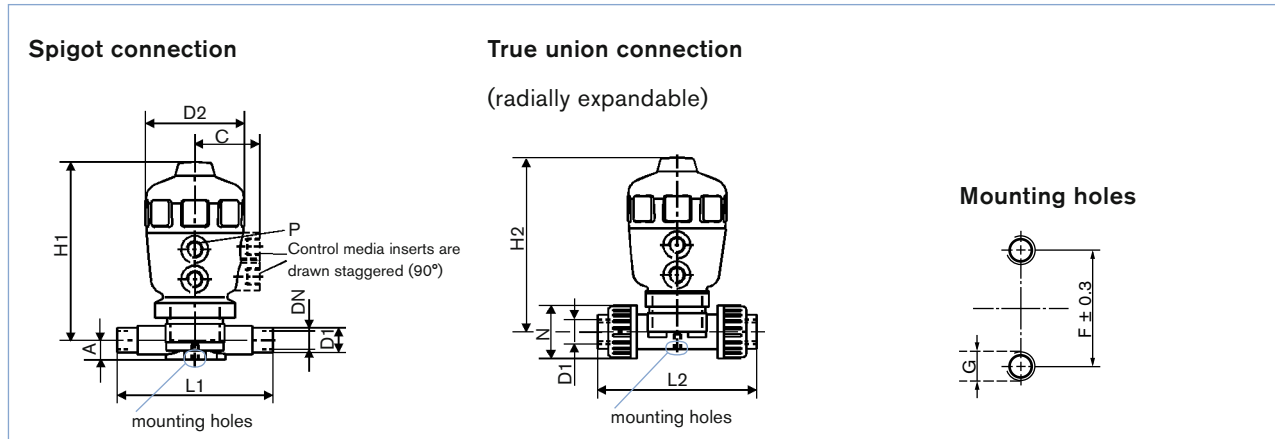

Orifice [mm] (diaphragm size)	All bodies							Spigot connection			True union connection		
	Actuator size Ø	C	D1	D2	P	F ±0.3	G	A	H1	L1	L2	H2	N
15	50	39	20	64	G 1/8	25	M6	14	121	124	128	123	43
	63	52	20	80	G 1/4	25	M6	14	137	124	128	139	43
20	63	52	25	80	G 1/4	25	M6	18	146	144	152	148	53
	80	60	25	101	G 1/4	25	M6	18	172	144	152	173	53
25	80	60	32	101	G 1/4	25	M6	21	175	154	166	176	60
32	100	73	40	127	G 1/4	45	M8	26	229	174	192	231	74
40	100	73	50	127	G 1/4	45	M8	33	236	194	222	239	83
	125	86	50	153	G 1/4	45	M8	33	276	194	222	277	83
50	125	86	63	153	G 1/4	45	M8	39	283	224	266	284	103

DN 65-100

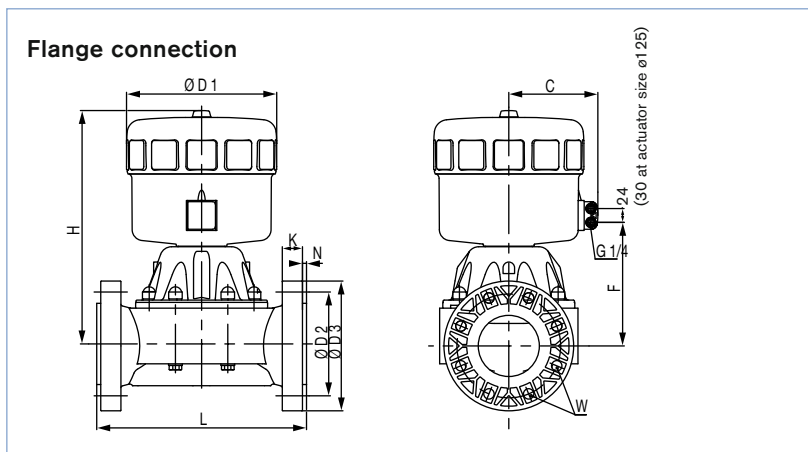

Orifice [mm] (diaphragm size)	Actuator size	Port connection	C	D1	D2	D3	F	H	K	L	W
65	125	Loose flanges	86	158	145	185	129	295	29	290	4 x 90°
	175	Loose flanges	130	211	145	185	180	387	29	290	4 x 90°
80	175	Fixed flanges	130	211	160	200	197	398	36	310	8 x 45°
	225	Fixed flanges	155	261	160	200	198	393	36	310	8 x 45°
100	225	Fixed flanges	155	261	180	225	210	410	36	350	8 x 45°

To find your nearest Bürkert facility, click on the orange box → www.burkert.com

In case of special application conditions, please consult for advice.

Subject to alteration.
© Christian Bürkert GmbH & Co. KG

1509/14_EU-en_00891670